

SET-UP SHEET

#95696

S400

NAME Michael "Butter" Abraira

RACE FSEARA Race 2

TRACK Village R/C Raceway

SURFACE ASPHALT CARPET

COMMENTS

MOTOR Novak Velociti 10.5

ESC Novak GTB

CELLS ENER G 4600

COMMENTS Car had plenty of traction in the heat. Could have used a bit more entry steering (softer front spring)

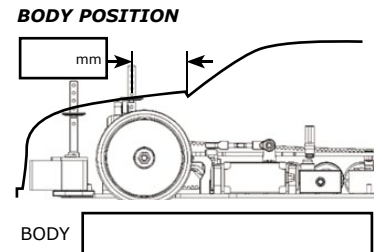

FRONT

SERVO SAVER



SHOCK ABSORBERS

Holes

Oil Xray 30wt

Spring Orange

FRONT AXLE

Ball Diff

LOOSE TIGHT

Solid Axle

One Way

CAMBER

L 1.2 °

R 1.2 °

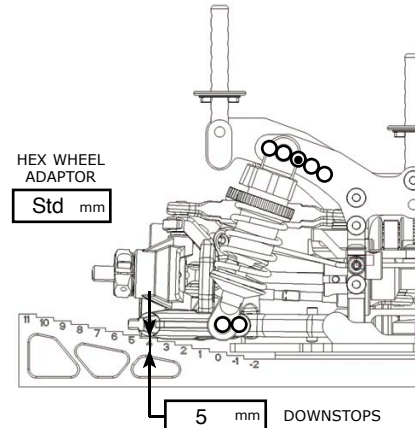
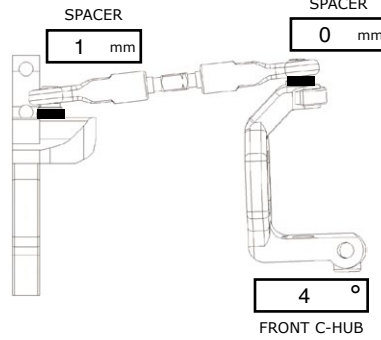
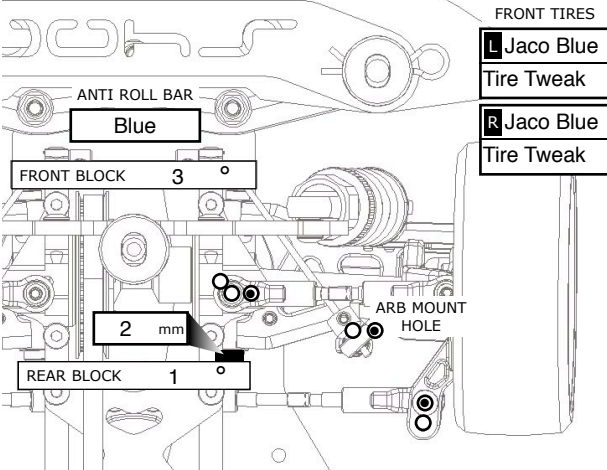
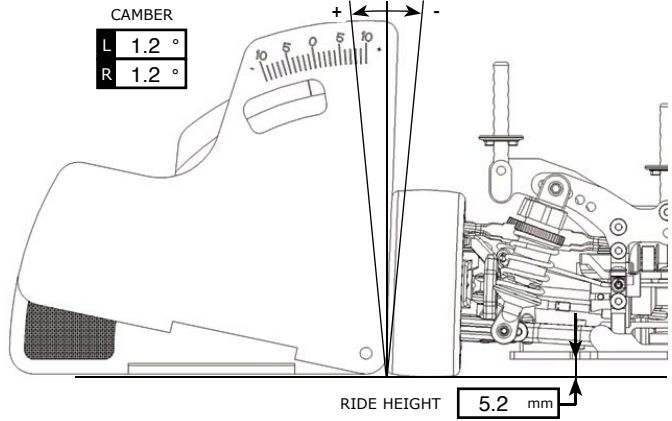

REAR

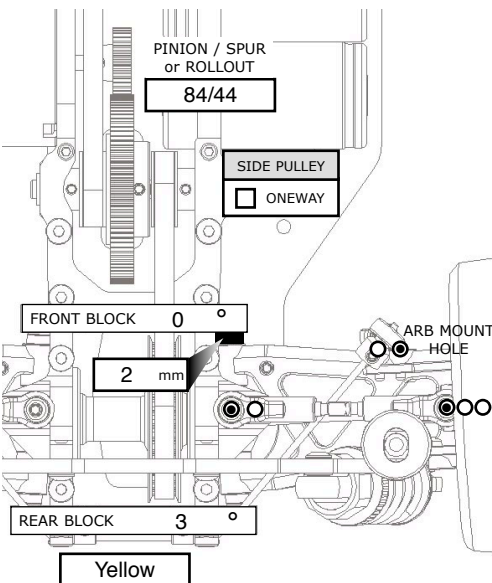

REAR TIRES

L Jaco Blue
Tire Tweak

R Jaco Blue
Tire Tweak

REAR AXLE

Ball Diff

LOOSE TIGHT

Solid Axle

Gear Diff

5000 Wt cst

SHOCK ABSORBERS

Holes

Oil Xray 30wt

Spring Yellow

